

<i>SUMMARY</i>			
BODY WIDTH	LEAD PITCH	LEAD COUNT	VARIATIONS
4.40	0.65	8	AA
		14	AB-1
		16	AB
		20	AC
		24	AD
		28	AE
	0.50	38	BD-1
6.10	0.50	48	ED
		56	EE

FOR REVISION UPDATE PLEASE REFER TO HISTORY OF CHANGES.

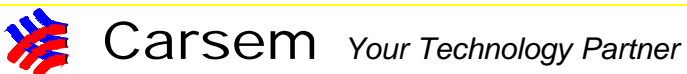

REV G	DWG NO: PKGTS0001			FILE: \PKGTS0001
	APP'D	KH LEE		<i>TSSOP PACKAGE OUTLINE</i>
	CHECKED	ARAVEN		
	DESIGNED	ARAVEN		
	DRAWN	KHALIM		
			PAGE: 1 OF 5	

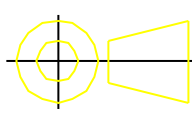
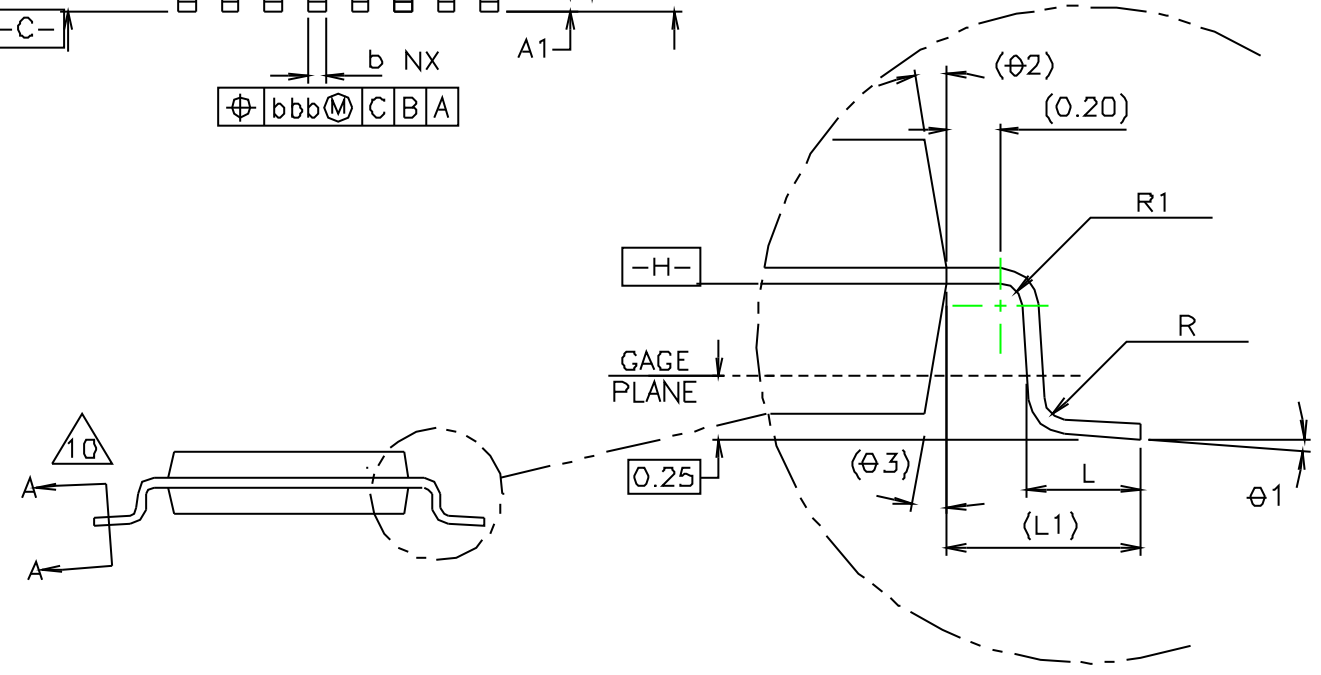
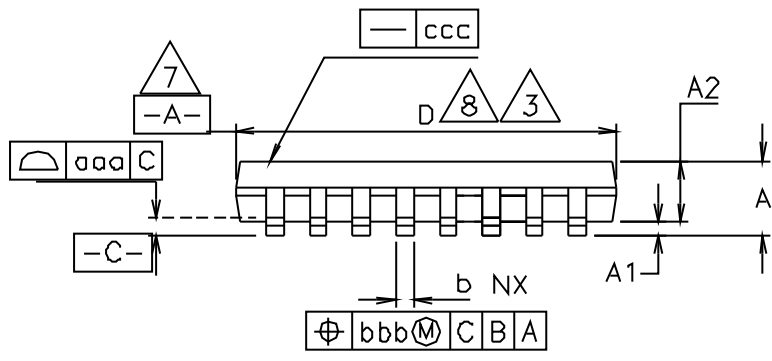
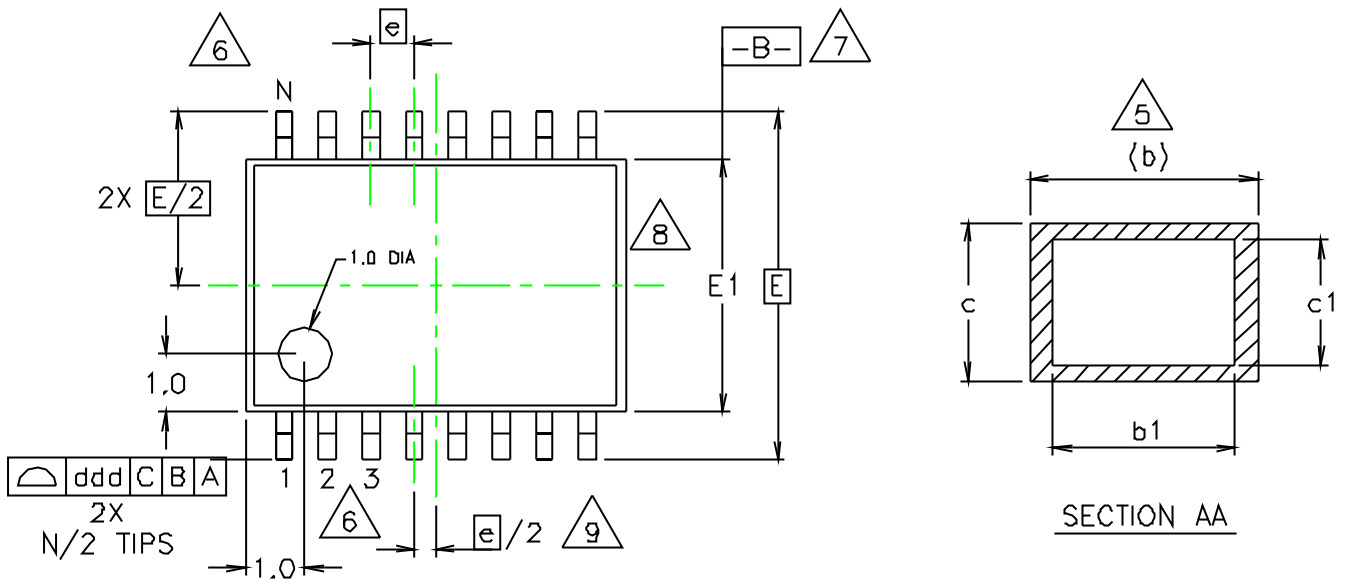

FOR REVISION UPDATE PLEASE REFER TO HISTORY OF CHANGES.



REV G	DWG NO: PKGTS0001		FILE: \PKGTS0001
	APP'D	KH LEE	TSSOP PACKAGE OUTLINE
	CHECKED	ARAVEN	
	DESIGNED	ARAVEN	PAGE: 2 OF 5
	DRAWN	KHALIM	

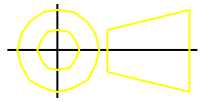

SYMBOL	COMMON DIMENSION(MILLIMETERS)							
	0,65mm LEAD PITCH			NOTE	0,50mm LEAD PITCH			NOTE
	MIN	NOM	MAX		MIN	NOM	MAX	
A	---	---	1.10	---	---	---	1.10	---
A1	0.05	---	0.15	---	0.05	---	0.15	---
A2	0.85	0.90	0.95	---	0.85	0.90	0.95	---
L	0.50	0.60	0.75	---	0.45	0.60	0.75	---
R	0.09	---	---	---	0.09	---	---	---
R1	0.09	---	---	---	0.09	---	---	---
b	0.19	---	0.30	5	0.17	---	0.27	5
b1	0.19	0.22	0.25	---	0.17	0.20	0.23	---
c	0.09	---	0.20	---	0.09	---	0.20	---
c1	0.09	---	0.16	---	0.09	---	0.16	---
$\theta 1$	0°	---	8°	---	0°	---	8°	---
L1	1.0 REF			---	1.0 REF			---
aaa	0,10			---	0,10			---
bbb	0,10			---	0,08			---
ccc	0,05			---	0,05			---
ddd	0,20			---	0,20			---
e	0.65 BSC			---	0.50 BSC			---
$\theta 2$	12° REF			---	12° REF			---
$\theta 3$	12° REF			---	12° REF			---
NOTE	1,2				1,2			
ISSUE	A				A			

FOR REVISION UPDATE PLEASE REFER TO HISTORY OF CHANGES.

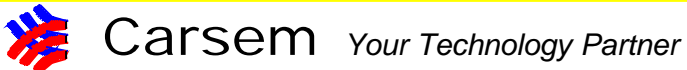

REV
G

DWG NO: PKGTS0001	
APP'D	KH LEE
CHECKED	ARAVEN
DESIGNED	ARAVEN
DRAWN	KHALIM

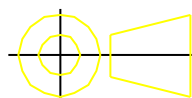

FILE: \PKGTS0001

TSSOP
PACKAGE OUTLINE

PAGE: 3 OF 5

NOTES:

- 1 ALL DIMENSIONS ARE IN MILLIMETERS (ANGLES IN DEGREES).
- 2 DIMENSIONING AND TOLERANCING PER ASME Y14.5M-1994.
- 3 DIMENSION 'D' DOES NOT INCLUDE MOLD FLASH, PROTRUSIONS OR GATE BURRS. MOLD FLASH, PROTRUSIONS OR GATE BURRS SHALL NOT EXCEED 0.15 PER SIDE.
- 4 DIMENSION 'E1' DOES NOT INCLUDE INTERLEAD FLASH OR PROTRUSION, INTERLEAD FLASH OR PROTRUSION SHALL NOT EXCEED 0.25 PER SIDE.
- 5 DIMENSION 'b' DOES NOT INCLUDE DAMBAR PROTRUSION, ALLOWABLE DAMBAR PROTRUSION SHALL BE 0.08 MM TOTAL IN EXCESS OF THE 'b' DIMENSION AT MAXIMUM MATERIAL CONDITION. DAMBAR CANNOT BE LOCATED ON THE LOWER RADIUS OF THE FOOT. MINIMUM SPACE BETWEEN PROTRUSION AND ADJACENT LEAD IS 0.07 MM FOR 0.5 MM PITCH PACKAGES.
- 6 TERMINAL NUMBERS ARE SHOWN FOR REFERENCE ONLY.
- 7 DATUMS -A- AND -B- TO BE DETERMINED AT DATUM PLANE -H-
- 8 DIMENSIONS 'D' AND 'E1' ARE TO BE DETERMINED AT DATUM PLANE -H-
- 9 THIS DIMENSION APPLIES ONLY TO VARIATIONS WITH AN EVEN NUMBER OF LEADS PER SIDE. FOR VARIATION WITH AN ODD NUMBER OF LEADS PER SIDE, THE "CENTER" LEAD MUST BE COINCIDENT WITH THE PACKAGE CENTERLINE, DATUM A.
- 10 CROSS SECTION A-A TO BE DETERMINED AT 0.10 TO 0.25 MM FROM THE LEAD TIP.
- 11 THIS VARIATION IS NOT REGISTERED WITH JEDEC.

FOR REVISION UPDATE PLEASE REFER TO HISTORY OF CHANGES.

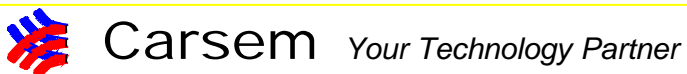

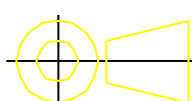
REV G	DWG NO: PKGTS0001			FILE: \PKGTS0001
	APP'D	KH LEE		TSSOP PACKAGE OUTLINE
	CHECKED	ARAVEN		
	DESIGNED	ARAVEN		
	DRAWN	KHALIM		
			PAGE: 4 OF 5	

SYMBOL	VARIATIONS											
	AA			NOTE	AB-1			NOTE	AB			NOTE
	MIN	NOM	MAX		MIN	NOM	MAX		MIN	NOM	MAX	
D	2.90	3.0	3.10	3,8	4.90	5.00	5.10	3,8	4.90	5.00	5.10	3,8
E1	4.30	4.40	4.50	4,8	4.30	4.40	4.50	4,8	4.30	4.40	4.50	4,8
E	6.4 BSC				6.4 BSC				6.4 BSC			
e	0.65 BSC				0.65 BSC				0.65 BSC			
N	8			6	14			6	16			6
NOTE	1,2				1,2				1,2			
ISSUE	A				C				A			

SYMBOL	VARIATIONS											
	AC			NOTE	AD			NOTE	AE			NOTE
	MIN	NOM	MAX		MIN	NOM	MAX		MIN	NOM	MAX	
D	6.40	6.50	6.60	3,8	7.70	7.80	7.90	3,8	9.60	9.70	9.80	3,8
E1	4.30	4.40	4.50	4,8	4.30	4.40	4.50	4,8	4.30	4.40	4.50	4,8
E	6.4 BSC				6.4 BSC				6.4 BSC			
e	0.65 BSC				0.65 BSC				0.65 BSC			
N	20			6	24			6	28			6
NOTE	1,2				1,2				1,2			
ISSUE	A				A				A			

SYMBOL	VARIATIONS											
	BD-1			NOTE	ED			NOTE	EE			NOTE
	MIN	NOM	MAX		MIN	NOM	MAX		MIN	NOM	MAX	
D	9.60	9.70	9.80	3,8	12.40	12.50	12.60	3,8	13.90	14.00	14.10	3,8
E1	4.30	4.40	4.50	4,8	6.00	6.10	6.20	4,8	6.00	6.10	6.20	4,8
E	6.4 BSC				8.1 BSC				8.1 BSC			
e	0.50 BSC				0.50 BSC				0.50 BSC			
N	38			6	48			6	56			6
NOTE	1,2,11				1,2				1,2			
ISSUE	---				A				A			

FOR REVISION UPDATE PLEASE REFER TO HISTORY OF CHANGES.

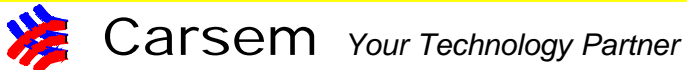

REV
G

DWG NO: PKGTS0001	
APP'D	KH LEE
CHECKED	ARAVEN
DESIGNED	ARAVEN
DRAWN	KHALIM

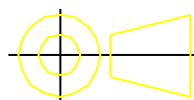

FILE: \PKGTS0001

TSSOP
PACKAGE OUTLINE

PAGE: 5 OF 5