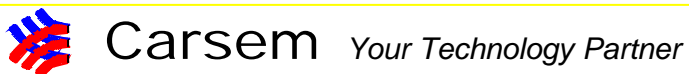

FIGURE 1
PRINCIPAL DIMENSIONS
AND DATUMS

FOR REVISION UPDATE PLEASE REFER TO HISTORY OF CHANGES.



REV
C

DWG NO: PKGPL0004	
APP'D	KH LEE
CHECKED	ARAVEN
DESIGNED	ARAVEN
DRAWN	KHALIM

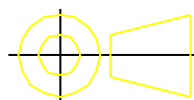

FILE: \PKGPL0004
PLCC PACKAGE OUTLINE
PAGE: 1 OF 6

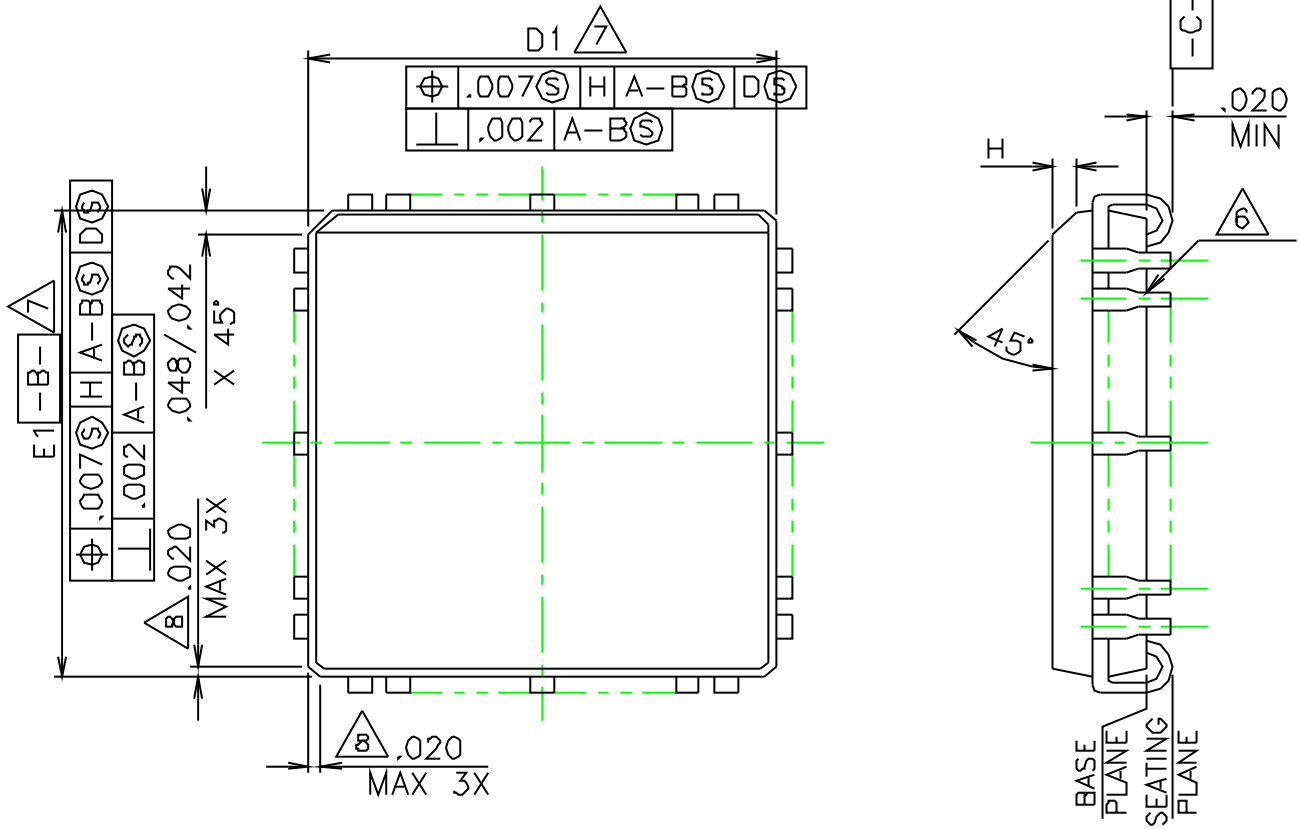
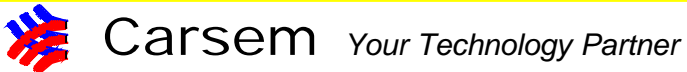

FIGURE 2
MOLDED DETAILS

FOR REVISION UPDATE PLEASE REFER TO HISTORY OF CHANGES.



REV
C

DWG NO: PKGPL0004	
APP'D	KH LEE
CHECKED	ARAVEN
DESIGNED	ARAVEN
DRAWN	KHALIM

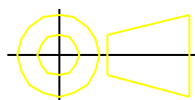

FILE: \PKGPL0004
PLCC
PACKAGE OUTLINE

PAGE: 2 OF 6

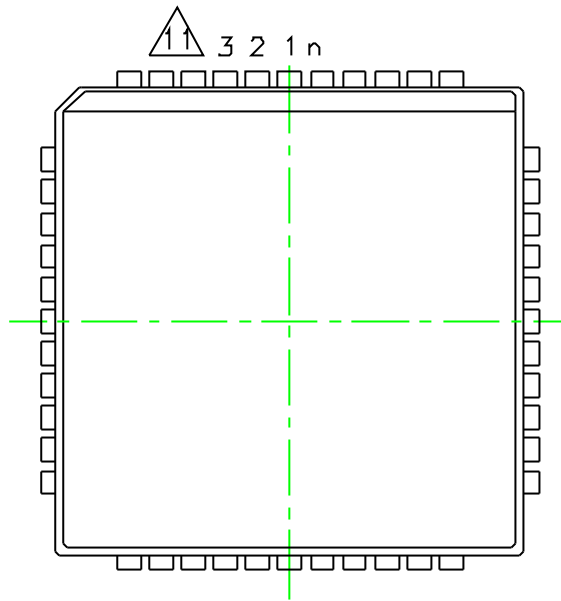

TOP VIEW

FIGURE 4
PIN NUMBERING

FIGURE 3
TERMINAL DETAILS

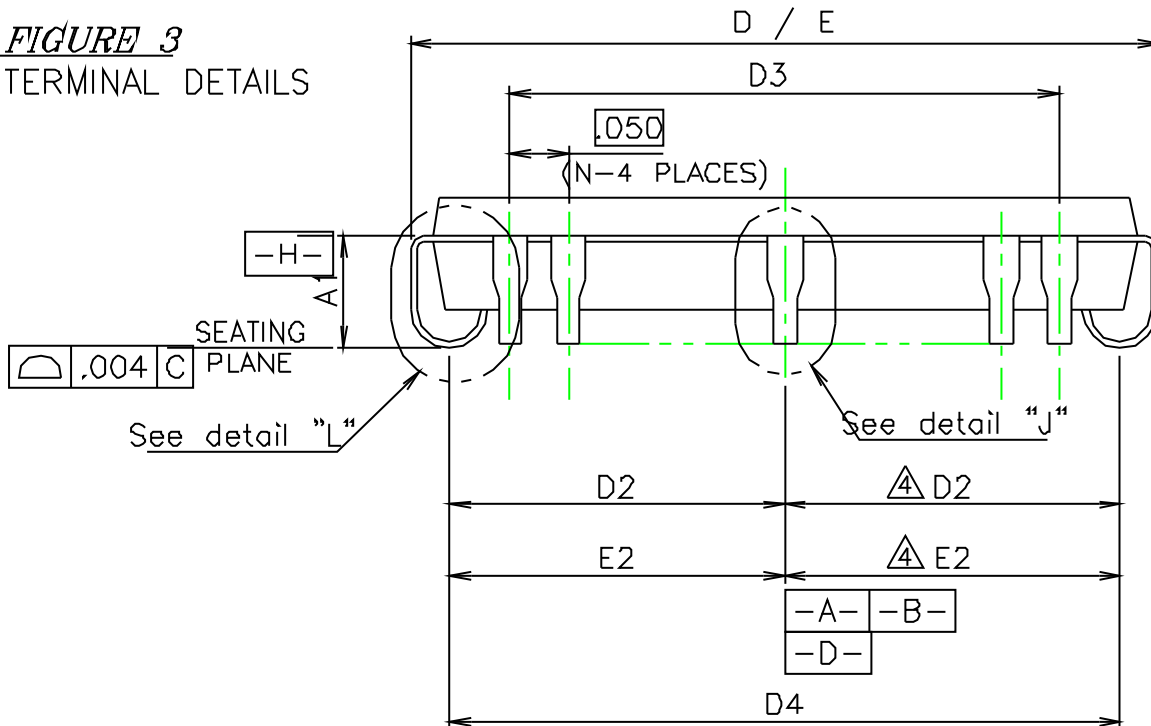

FOR REVISION UPDATE PLEASE REFER TO HISTORY OF CHANGES.

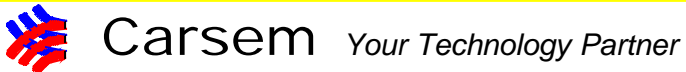

REV
C

DWG NO: PKGPL0004	
APP'D	KH LEE
CHECKED	ARAVEN
DESIGNED	ARAVEN
DRAWN	KHALIM

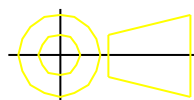

FILE: \PKGPL0004
PLCC
PACKAGE OUTLINE

PAGE: 3 OF 6

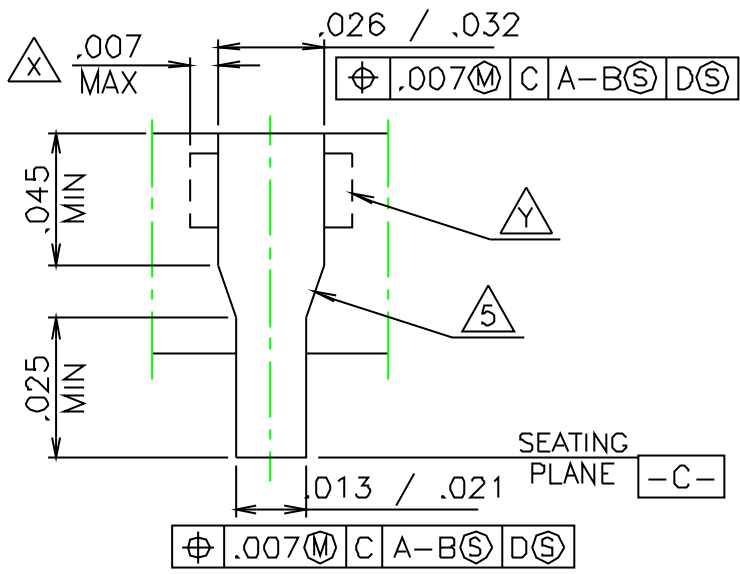

X SUM OF DAMBAR PROTRUSIONS TO BE .007 MAX/LEAD
 Y THIS FEATURE IS A RESULT OF THE MANUFACTURING PROCESS AND MAY NOT BE PRESENT. A MINIMUM SPACE OF .008 IS REQUIRED BETWEEN ADJACENT LEADS.

DETAIL J
TYP ALL SIDES

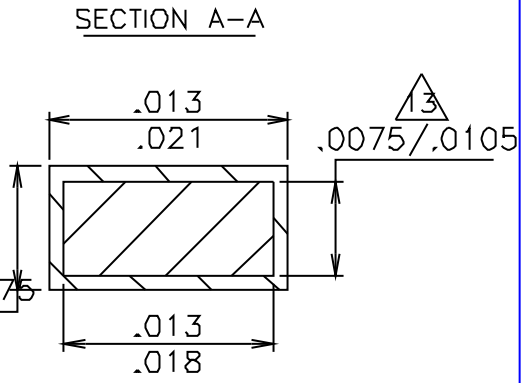
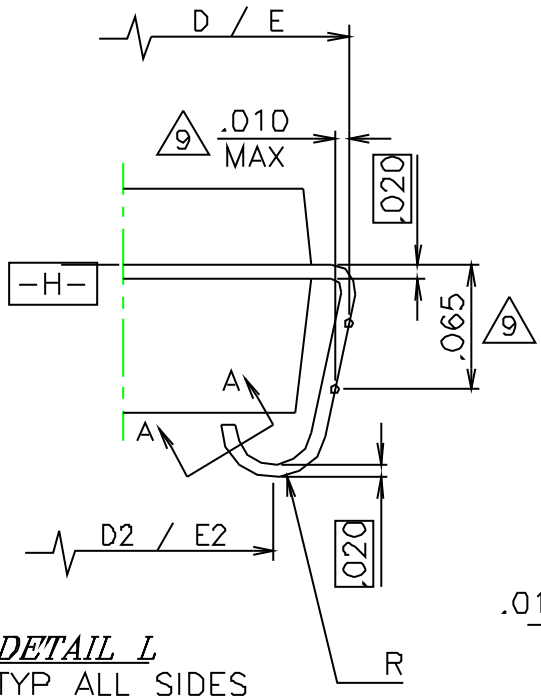

DETAIL L
TYP ALL SIDES

FOR REVISION UPDATE PLEASE REFER TO HISTORY OF CHANGES.



REV	
C	

DWG NO: PKGPL0004	
APP'D	KH LEE
CHECKED	ARAVEN
DESIGNED	ARAVEN
DRAWN	KHALIM

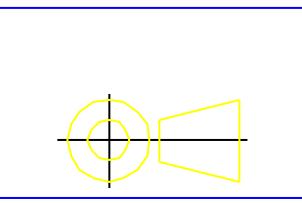

FILE: \PKGPL0004
PLCC PACKAGE OUTLINE
PAGE: 4 OF 6

NOTES:

- 1 ALL DIMENSIONS AND TOLERANCES CONFORM TO ANSI Y14.5M-1982.
- 2 DATUM PLANE -H- LOCATED AT TOP OF MOLD PARTING LINE AND COINCIDENT WITH TOP OF LEAD WHERE LEAD EXITS PLASTIC BODY.
- 3 DATUMS A-B AND -D- TO BE DETERMINED WHERE CENTER LEADS EXIT PLASTIC BODY AT DATUM PLANE -H-
- 4 TO BE MEASURED AT SEATING PLANE -C- CONTACT POINT.
- 5 SHAPE OF TRANSITION IS OPTIONAL.
- 6 PLASTIC BODY DETAILS BETWEEN LEADS ARE OPTIONAL.
- 7 DIMENSIONS D1 AND E1 DO NOT INCLUDE MOLD PROTRUSION.ALLOWABLE MOLD PROTRUSION IS .010" PER SIDE.DIMENSIONS D1 AND E1 INCLUDE MOLD MISMATCH AND ARE DETERMINED AT THE PARTING LINE , THAT IS D1 AND E1 ARE MEASURED AT THE EXTREME MATERIAL CONDITION AT THE UPPER OR LOWER PARTING LINE.
- 8 EXACT SHAPE OF THIS FEATURE IS OPTIONAL.
- 9 THESE TWO DIMENSIONS DETERMINE MAXIMUM ANGLE OF THE LEAD FOR CERTAIN SOCKET APPLICATIONS.IF UNIT IS INTENDED TO BE SOCKETED,IT IS ADVISABLE TO REVIEW THESE DIMENSIONS WITH SOCKET SUPPLIER.
- 10 ALL DIMENSIONS IN INCHES.
- 11 PIN NUMBERS ARE FOR REFERENCE ONLY.
- 12 DIMENSION R REQUIRED FOR 120° MINIMUM BEND.
- 13 DIMENSION APPLIES TO BASE METAL ONLY.

FOR REVISION UPDATE PLEASE REFER TO HISTORY OF CHANGES.

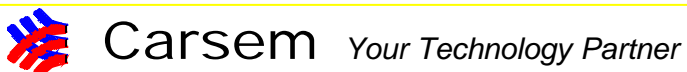

REV C	DWG NO: PKGPL0004			FILE: \PKGPL0004
	APP'D	KH LEE		PLCC PACKAGE OUTLINE
	CHECKED	ARAVEN		
	DESIGNED	ARAVEN		
	DRAWN	KHALIM		
			PAGE: 5 OF 6	

VARIATIONS												
SYMBOL	AB			AC			AD			AE		
	MIN	NOM	MAX	MIN	NOM	MAX	MIN	NOM	MAX	MIN	NOM	MAX
A	.165	.172	.180	.165	.172	.180	.165	.172	.180	.165	.172	.180
A1	.090	.105	.120	.090	.105	.120	.090	.105	.120	.090	.105	.120
D	.485	.490	.495	.685	.690	.695	.785	.790	.795	.985	.990	.995
D1	.450	.453	.456	.650	.653	.656	.750	.753	.756	.950	.954	.958
D2	.191	.205	.219	.291	.305	.319	.341	.355	.369	.441	.455	.469
D3	.300 REF			.500 REF			.600 REF			.800 REF		
D4	.390	.410	.430	.590	.610	.630	.690	.710	.730	.890	.910	.930
E	.485	.490	.495	.685	.690	.695	.785	.790	.795	.985	.990	.995
E1	.450	.453	.456	.650	.653	.656	.750	.753	.756	.950	.954	.958
E2	.191	.205	.219	.291	.305	.319	.341	.355	.369	.441	.455	.469
E3	.300 REF			.500 REF			.600 REF			.800 REF		
E4	.390	.410	.430	.590	.610	.630	.690	.710	.730	.890	.910	.930
H	.042	.049	.056	.042	.049	.056	.042	.049	.056	.042	.049	.056
R	.030	.035	.040	.030	.035	.040	.030	.035	.040	.030	.035	.040
N	28			44			52			68		

NOTE 1, 11

REF 11 - 252S

ISSUE A

VARIATIONS

SYMBOL	AF			AG			AH			AI		
	MIN	NOM	MAX	MIN	NOM	MAX	MIN	NOM	MAX	MIN	NOM	MAX
A	.165	.172	.180	.165	.172	.180						
A1	.090	.105	.120	.090	.105	.120						
D	1.185	1.190	1.195	.385	.390	.395						
D1	1.150	1.154	1.158	.350	.353	.356						
D2	.541	.555	.569	.141	.155	.169						
D3	1.000 REF			.200 REF								
D4	1.090	1.110	1.130	.290	.310	.330						
E	1.185	1.190	1.195	.385	.390	.395						
E1	1.150	1.154	1.158	.350	.353	.356						
E2	.541	.555	.569	.141	.155	.169						
E3	1.000 REF			.200 REF								
E4	1.090	1.110	1.130	.290	.310	.330						
H	.042	.049	.056	.042	.045	.048						
R	.030	.035	.040	.025	.035	.045						
N	84			20								

NOTE 1, 11

REF 11 - 252S

ISSUE A

FOR REVISION UPDATE PLEASE REFER TO HISTORY OF CHANGES.

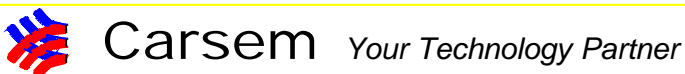

REV
C

DWG NO: PKGPL0004	
APP'D	KH LEE
CHECKED	ARAVEN
DESIGNED	ARAVEN
DRAWN	KHALIM

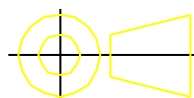

FILE: \PKGPL0004

PLCC
PACKAGE OUTLINE

PAGE: 6 OF 6